

# KCP COUPLINGS

[www.koreacoupling.co.kr](http://www.koreacoupling.co.kr)



# KW Flex Couplings



KCP KW Flex Coupling is designed to allow for quick and easy element replacement. Removal of hubs or the realignment of motors or drives is not required, which in turn reduces overall downtime.

Advanced production methods and innovative material selection allows for a higher capacity at a more competitive price.

KW Flex Coupling is non-lubricated and are designed from flexible urethane. The lack of need for lubrication decreases recurrent maintenance costs.

Available in both close-coupled and spacer designs, Urethane Flexible Couplings accommodate shaft diameters up to 186mm and torque loads up to 15,028 Nm

The urethane element has excellent resistance to wear and chemicals, and can be operated between temperatures of -40°C to 95°C.

The compact design of this coupling eliminates that need for coupling guard redesign for specific applications.

## KW Flex Coupling Types

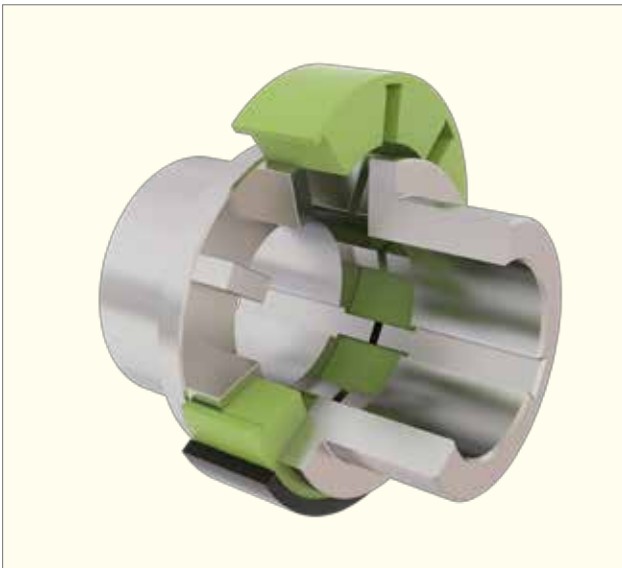

**KW10 Type**



**KW31 Type (Full Spacer)**



**KW35 Type (Half Spacer)**

# KW10 Type

## Close Coupled

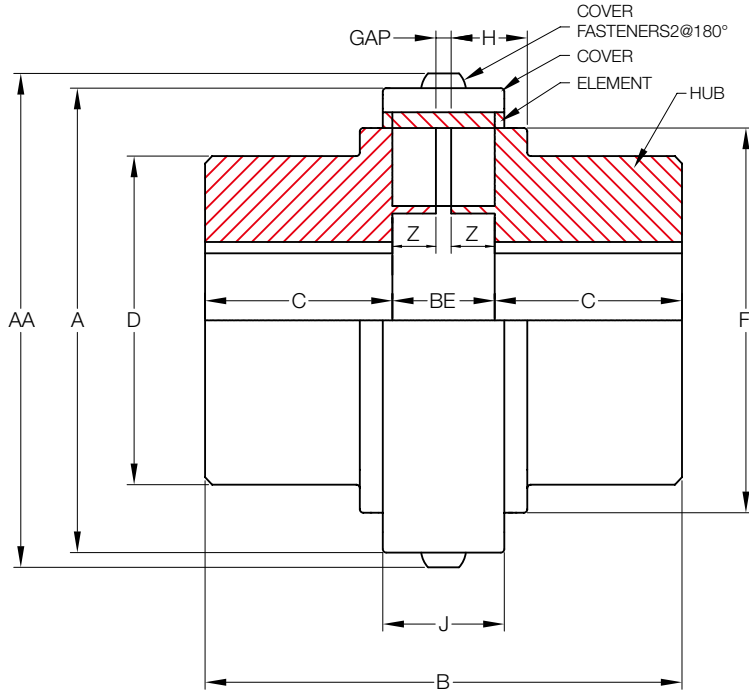

Size	Torque Rating (Nm)	Allow Speed RPM	Max Bore (mm)	Min Bore (mm)	Cplg Wt (Kg)		Dimensions (Millimeters)														Cover Fasteners	
					Nylon Cover	Steel Cover	A		AA		B	BE	C	D	F	H	J	Z	GAP	Size	Allen Wrench	
							Nylon	Steel	Nylon	Steel												
5R	62	4,500	38	12.7	1.35	1.49	76.5	76.5	80.5	80.4	71.9	19.8	25.9	59.9	64	15.0	23.1	8.9	2	M4	M2.5	
10R	130	4,500	48	15.88	2.49	2.72	90.4	90.4	94.5	94.4	91.9	23.9	34.0	72.1	75.9	19.1	27.9	10.9	2	M4	M2.5	
20R	316	4,500	60	19.05	5.64	6.09	126.0	124.0	132.0	130.0	121.9	32.0	45.0	91.9	102.1	24.9	37.1	15.0	2	M6	M4	
30R	520	4,500	65	25.40	9.41	10.00	146.6	143.0	153.0	149.0	151.9	36.1	57.9	104.9	118.1	29.0	41.9	17.0	2	M6	M4	
40R	1,028	3,600	85	28.58	17.10	18.10	182.1	177.0	190.0	185.0	181.1	47.0	67.1	130.0	150.1	34.0	54.6	21.1	5	M8	M5	
50R	2,508	3,000	105	31.75	35.80	37.70	230.9	224.0	239.0	232.0	214.9	60.7	77.0	178.1	190	46.0	69.6	27.9	5	M8	M5	
60R	4,011	2,500	135	50.80	-	66.40	-	267.0	-	278.0	275.3	75.4	100.1	209.6	228.1	60.2	67.1	35.3	5	M10	M6	
70R	8,011	2,100	160	69.85	-	111.00	-	310.0	-	321.0	324.1	84.1	119.9	251.0	270	69.6	74.9	39.6	5	M10	M6	
80R	15,027	1,800	190	85.73	-	166.00	-	370.0	-	381.0	376.9	97.0	140.0	270.0	327.9	83.3	85.1	45.5	6	M10	M6	

\* Coupling Weight is without Bore Machining

# KW31 Type

## Full Spacer

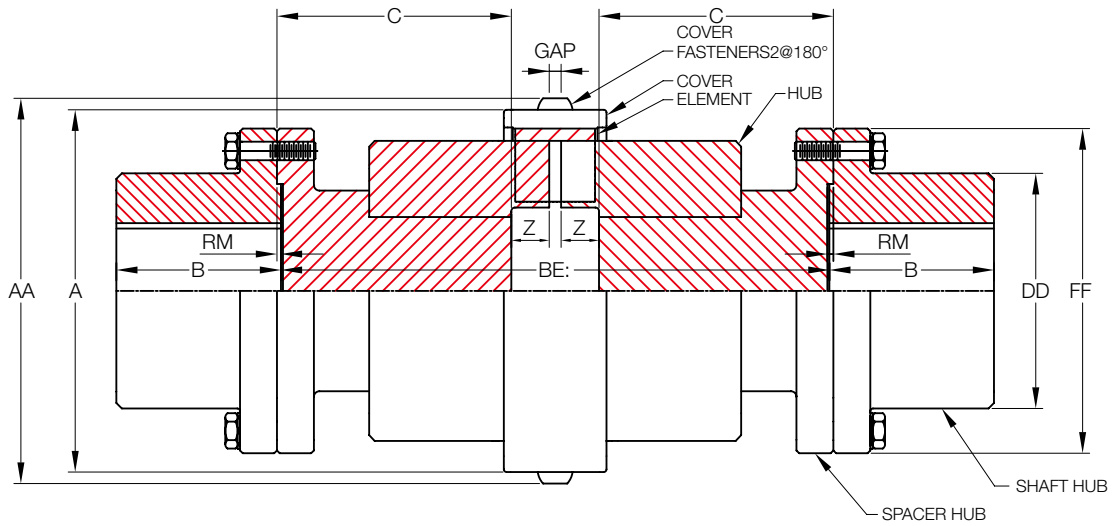

Size	Torque Rating (Nm)	Allow Speed RPM	Max Bore (mm)	Cplg Wt (Kg)		Dimensions (Millimeters)													Cover Fasteners		Flange Fasteners		T-Shaft Hub
				Min BE (Kg)	Add BE (Kg)	Distance Between Shaft Ends (BE) = 2(C) + 2(Z) + GAP - 2(RM)													Size	Allen Wrench	Size	Per Flange	
						Max	Min	Nylon	Steel	Nylon	Steel	B	BDD	FF	RM	S	Z	GAP					
5R	62	4,500	35	3.63	0.014	235	80.9	76.5	76.5	80.5	80.4	34.9	52.4	86	1.27	27.4	8.9	2	M4	M2.5	M6	4	1020T
10R	130	4,500	43	4.99	0.015	254	88.9	90.4	90.4	94.5	94.4	41.3	59.5	94	1.27	31.5	10.9	2	M4	M2.5	M6	8	1030T
20R	316	4,500	56	9.53	0.027	254	88.9	126.0	124.0	132.0	130.0	54.0	78.6	113	1.27	27.4	15.0	2	M6	M4	M6	8	1040T
30R	520	4,500	67	14.10	0.034	254	111.0	146.6	143.0	153.0	149.0	60.3	87.3	126	1.27	40.6	17.0	2	M6	M4	M8	8	1050T
40R	1,028	3,600	85	25.90	0.040	311	127.0	182.1	177.0	190.0	185.0	79.4	109.5	153	1.27	46.7	21.1	5	M8	M5	M10	12	1070T
50R	2,508	3,000	95	45.40	0.059	311	165.0	230.9	224.0	239.0	232.0	88.9	122.2	178	1.27	49.8	27.9	5	M8	M5	M12	12	1080T
60R	4,011	2,500	110	72.60	0.082	311	200.0	-	267.0	-	278.0	101.6	142.9	210	1.27	-	35.3	5	M10	M6	M16	12	1090T
70R	8,011	2,100	130	102.00	0.117	373	224.0	-	310.0	-	321.0	90.4	171.4	251	1.52	-	39.6	5	M10	M6	M20	12	1100T
70R	8,011	2,100	150	120.00	0.117	373	224.0	-	310.0	-	321.0	104.1	196.8	276	1.52	-	39.6	5	M10	M6	M20	12	1110T
80R	15,027	1,800	190	230.00	0.240	424	256.0	-	370.0	-	381.0	134.6	238.1	347	2.39	-	45.5	6	M10	M6	M27	12	1130T

\* Coupling Weight is without Bore Machining

# KW35 Type

## Half Spacer

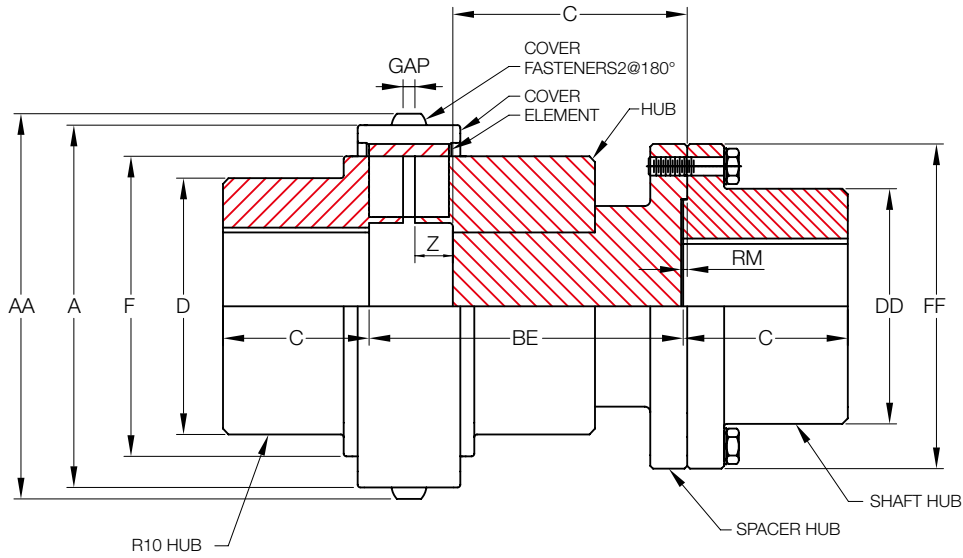

Size	Torque Rating (Nm)	Allow Speed RPM	Max Bore		Cplg Wt (Kg)		Dimensions (Millimeters)							
			T-Shaft Hub	KW10 Hub	Min BE (Kg)	Add BE (Kg)	Distance Between Shaft Ends (BE) = 2(C) + 2(Z) + GAP - 2(RM)							
							BE		A		AA		B	C KW10 Hub
5	62	4,500	35	38	2.54	0.014	127.0	50.5	76.5	76.5	80.5	80.4		
10	130	4,500	43	48	3.96	0.015	140.0	59.6	90.4	90.4	94.5	94.4	41.3	34.0
20	316	4,500	56	60	8.44	0.027	140.0	76.5	126.0	124.0	132.0	130.0	54.0	45.0
30	520	4,500	67	65	12.90	0.034	146.1	87.6	146.6	143.0	153.0	149.0	60.3	57.9
40	1,028	3,600	85	85	22.40	0.040	184.2	88.6	182.1	177.0	190.0	185.0	79.4	67.1
50	2,508	3,000	95	105	40.80	0.059	184.2	113.1	230.9	224.0	239.0	232.0	88.9	77.0
60	4,011	2,500	110	135	69.00	0.082	203.2	137.6	-	267.0	-	278.0	101.6	100.1
70	8,011	2,100	130	160	106.00	0.117	228.9	153.9	-	310.0	-	321.0	90.4	119.9
70	8,011	2,100	150	160	115.00	0.117	228.9	153.9	-	310.0	-	321.0	104.1	119.9
80	15,027	1,800	170	190	180.00	0.144	259.6	172.7	-	370.0	-	381.0	119.4	140.0
80	15,027	1,800	190	190	193.00	0.240	259.6	175.5	-	370.0	-	381.0	134.6	140.0

Size	Dimensions (Millimeters)									Cover Fasteners		Flange Fasteners		T-Shaft Hub	
	Distance Between Shaft Ends (BE) = 2(C) + 2(Z) + GAP - 2(RM)									Size	Allen Wrench	Size	Per Flange		
	D	DD	F	FF	RM	S		Z	GAP						
5	159.9	52.4	64.0	86	1.27	Shaft Hub	27.4	15.9	8.9	2	M4	M2.5	M6	4	1020T
10	72.1	59.5	75.9	94	1.27	KW10 Hub	31.5	22.2	10.9	2	M4	M2.5	M6	8	1030T
20	91.9	78.6	102.1	113	1.27		27.4	25.4	15.0	2	M6	M4	M6	8	1040T
30	104.9	87.3	118.1	126	1.27		40.6	31.8	17.0	2	M6	M4	M8	8	1050T
40	130.0	109.5	150.1	153	1.27		46.7	41.3	21.1	5	M8	M5	M10	12	1070T
50	178.1	122.2	190.0	178	1.27		49.8	44.5	27.9	5	M8	M5	M12	12	1080T
60	209.6	142.9	228.1	210	1.27		-	-	35.3	5	M10	M6	M16	12	1090T
70	251.0	171.4	270.0	251	1.52		-	-	39.6	5	M10	M6	M20	12	1100T
70	251.0	196.8	270.0	276	1.52		-	-	39.6	5	M10	M6	M20	12	1110T
80	270.0	225.4	327.9	320	2.39		-	-	45.5	6	M10	M6	M24	12	1120T
80	270.0	238.1	327.9	347	2.39		-	-	45.5	6	M10	M6	M27	12	1130T

\* Coupling Weight is without Bore Machining